

WIS-30 Wireless Infrared Sensors User Manual

Packing List

Sensor	1 pair
User Manual	1 pc
Jumper cap	1 pc
Gasket	M4*8*1 4pc
Rubber	1pcs
3*8 Screw(black color)	2pcs
Plastic wall plug	2pcs
3.5*20 Screw(silver Color)	2pcs

Installation:(Unit:mm)

Transmit:

- ◇ Please fix the bottom case to the wall according to the installation drawing.
- ◇ Install the AA battery in the battery compartment and install it into the bottom case.
- ◇ Install the cover and lock the bottom screw.

Receiver:

- ◇ Fix the bottom case to the wall and install the receiving board. At this time, we can set the output signal mode as needed, Please refer to the wiring definition details.

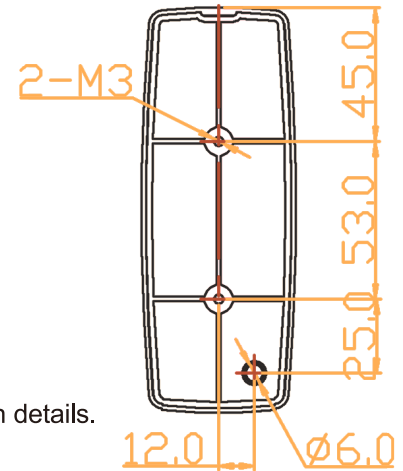

Receiver LED Indicator

LED	Function
Flashing	Not Transmit
Turn off	Receive a signal from Transmit

Connection Details

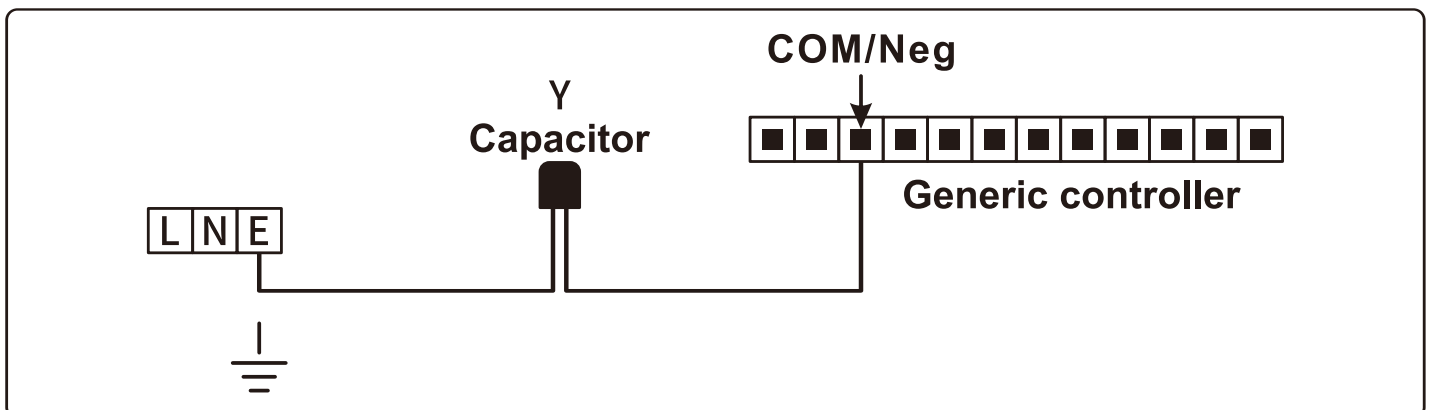

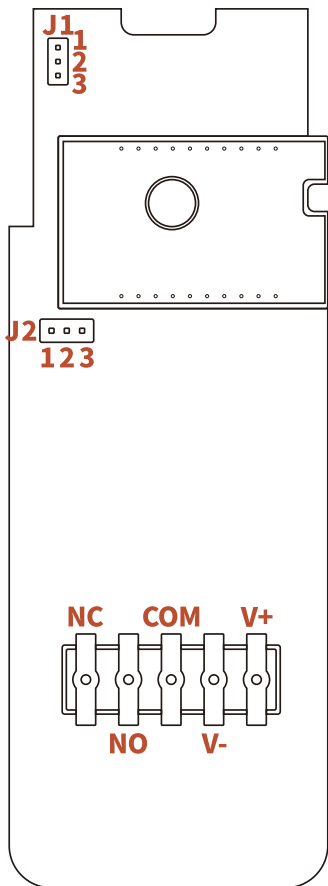

Receiver Jumper And Connection

Jumper	Point	Function
J1	2,3 with cap	Relay reverse output
	2,3 without cap	Relay normal output
J2	1,2 with cap	NPN output
	2,3 with cap	Relay output

Connection	Function
NC	Relay NC contact
NO	Relay NO contact
COM	Relay Com contact
V-	Power supply input -
V+	Power supply input +